

(No Model.)

4 Sheets—Sheet 1.

F. RATTEK.
LOCOMOTIVE ENGINE WHEEL LATHE.

No. 463,995.

Patented Nov. 24, 1891.

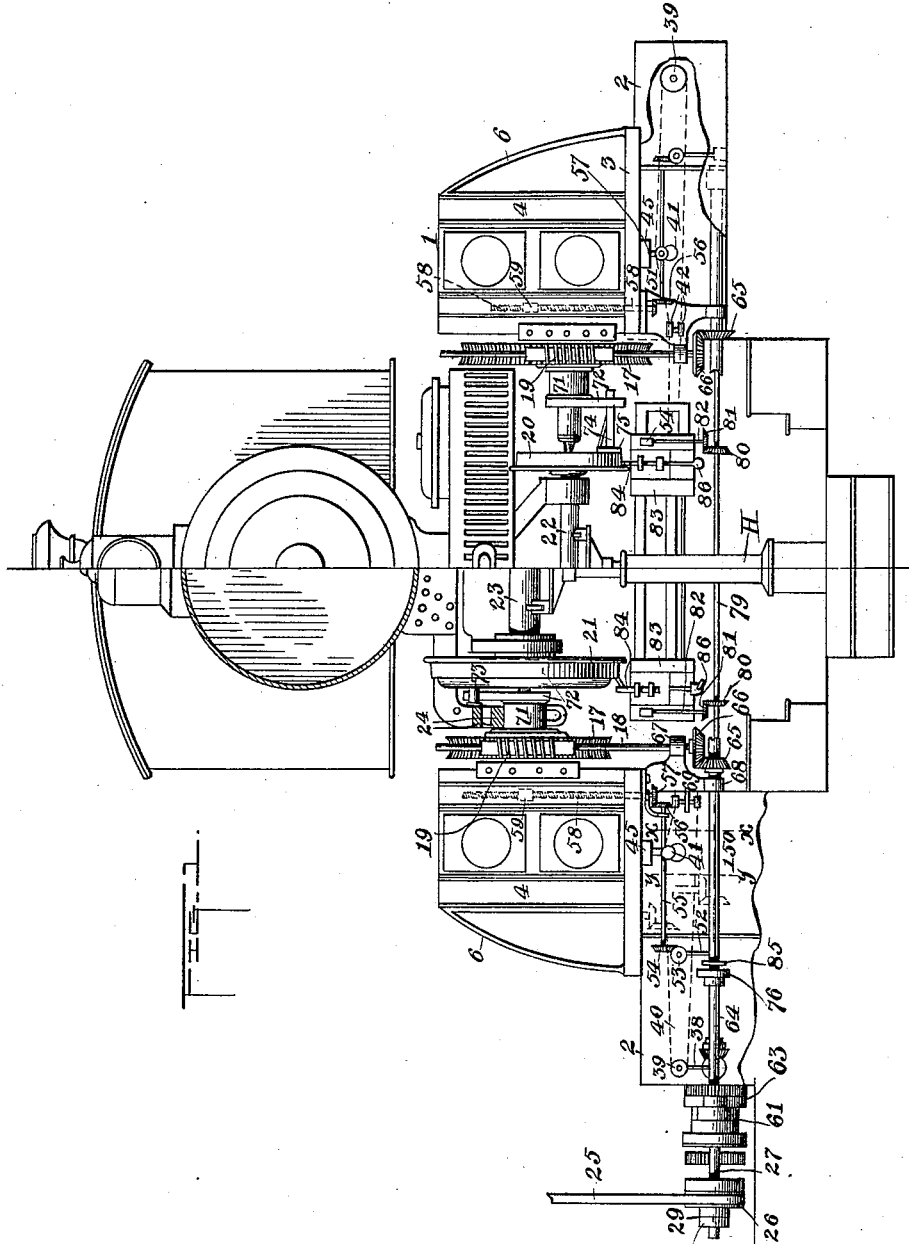

WITNESSES

Witnesses:
H. E. Aughinbaugh.
Edwin Bradford

INVENTOR

Frank Rattek.
 by *A. J. O'Brien*
Att'y.

(No Model.)

4 Sheets—Sheet 2.

F. RATTEK.
LOCOMOTIVE ENGINE WHEEL LATHE.

No. 463,995.

Patented Nov. 24, 1891.

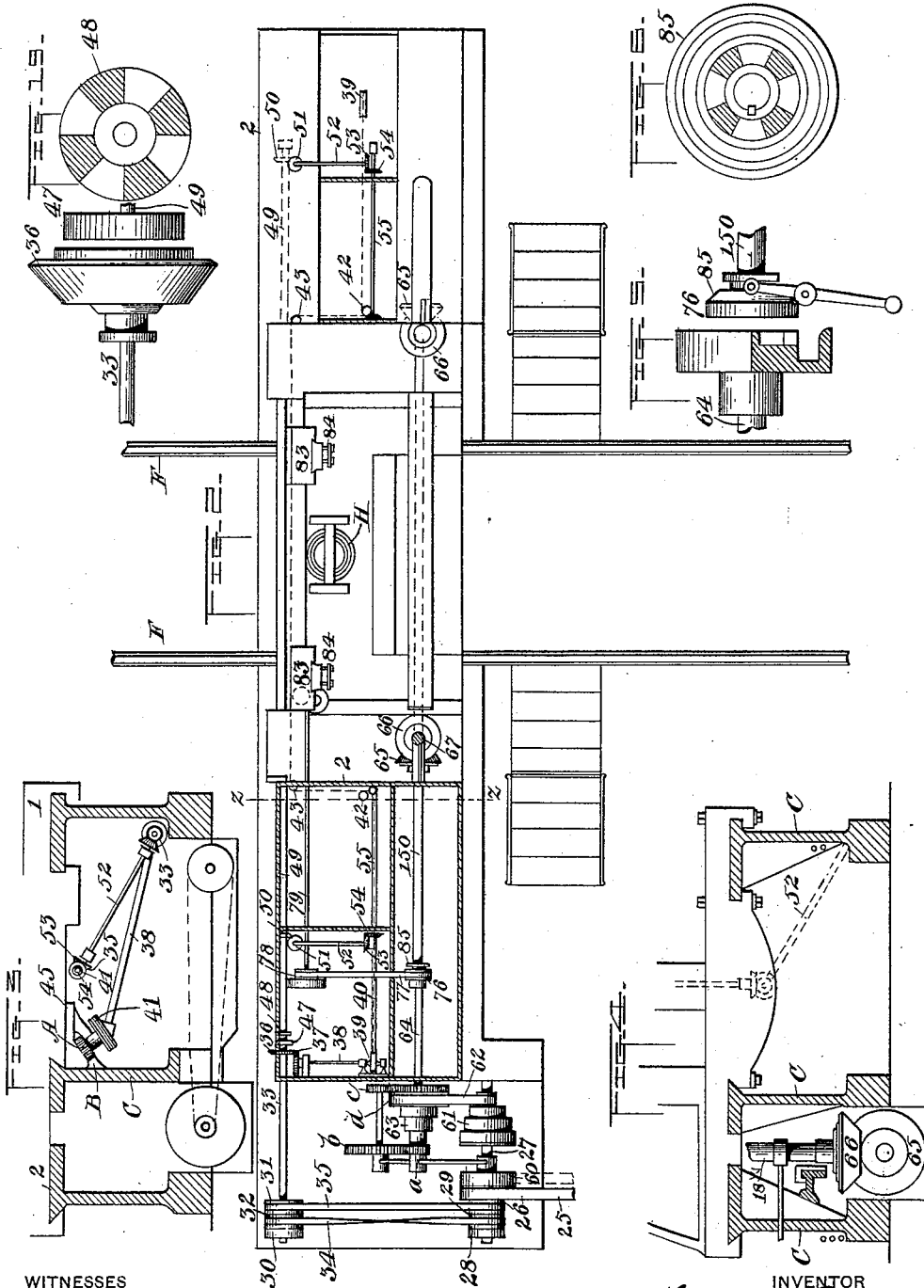

WITNESSES

Witnesses:
 H. E. Aughinbaugh
 Edwin Bradford

INVENTOR

Inventor:
 Frank Rattek
 by A. J. O'Brien atty.

(No Model.)

4 Sheets—Sheet 3.

F. RATTEK. LOCOMOTIVE ENGINE WHEEL LATHE.

No. 463,995.

Patented Nov. 24, 1891.

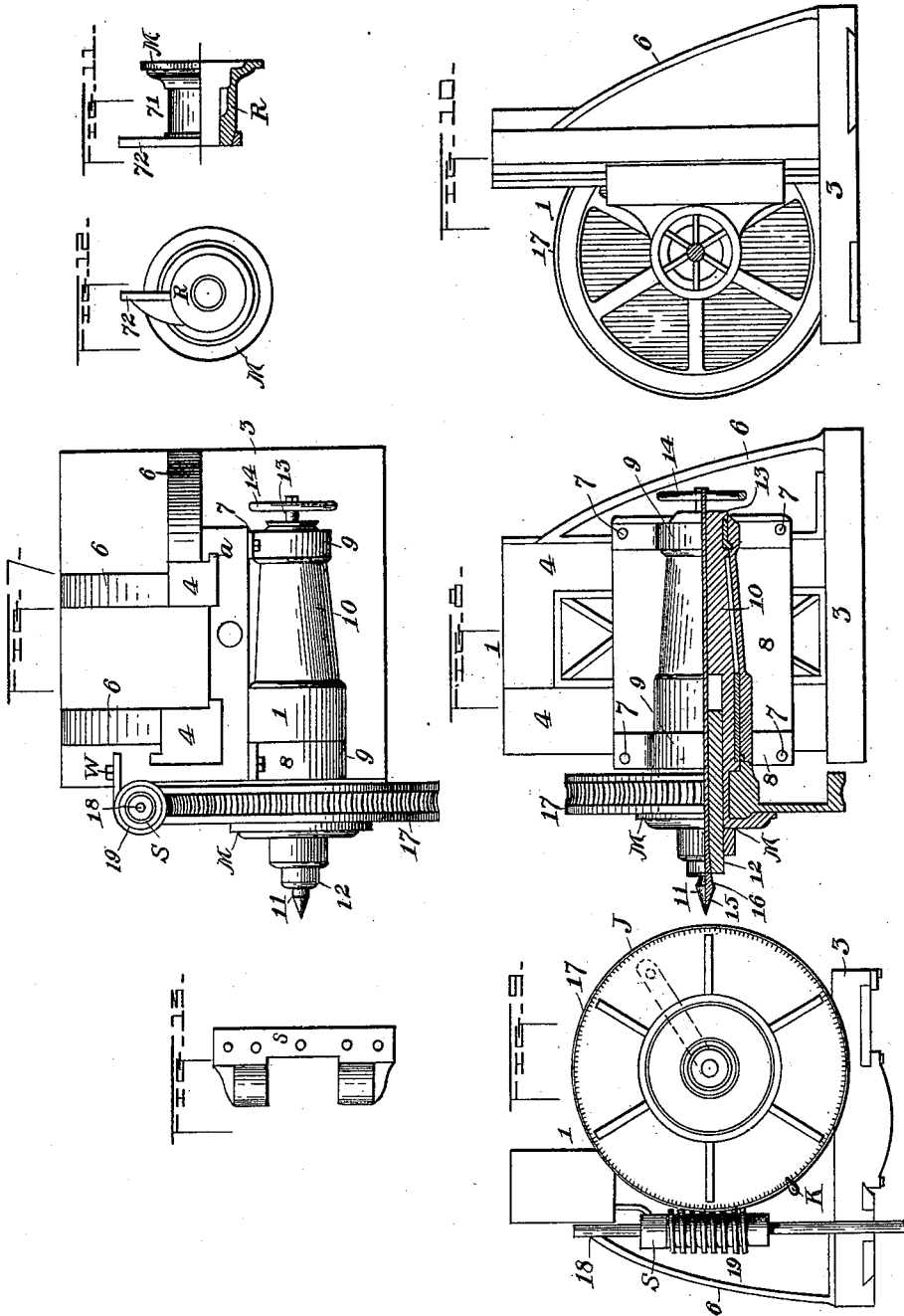

WITNESSES

George
H. E. Aughins
Edwin L. Bradford

INVENTOR

Frank Rattek
 by *A. J. O'Brien*
att.

F. RATTEK. LOCOMOTIVE ENGINE WHEEL LATHE.

No. 463,995.

Patented Nov. 24, 1891.

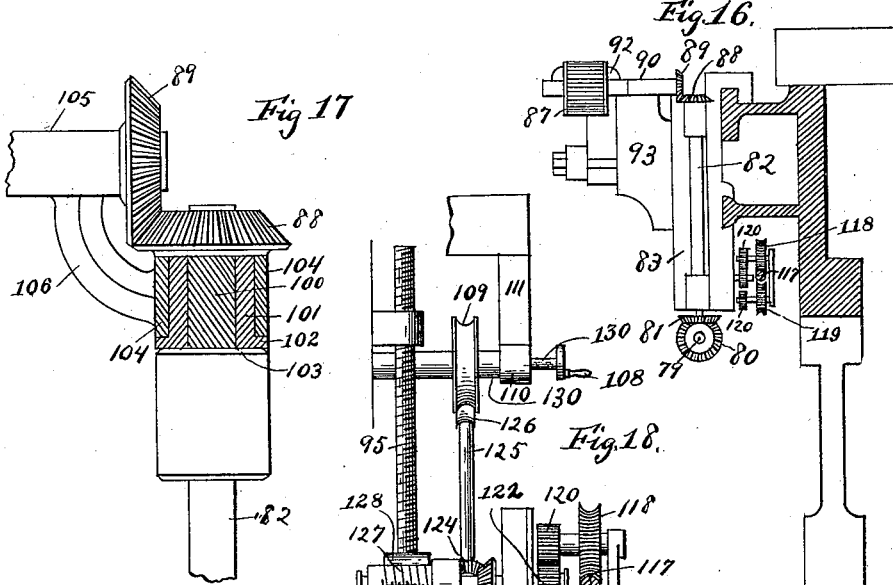
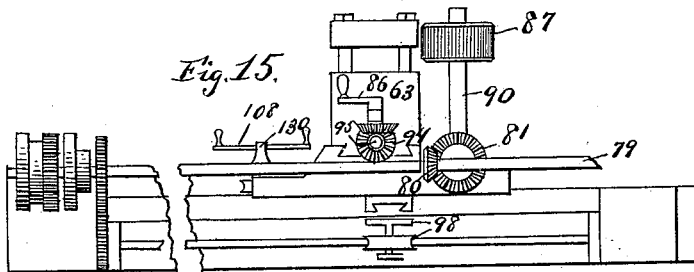
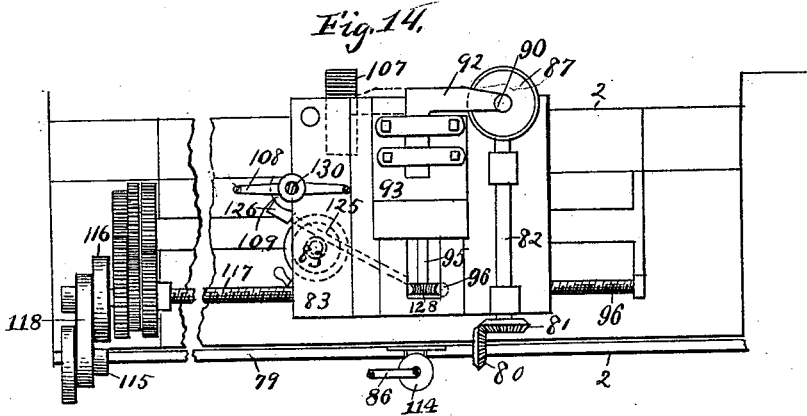

WITNESSES:

Chas. F. Miller.
W. E. Aughinbaugh

INVENTOR

Frank Rattek
 BY
A. J. O'Brien.
 ATTORNEY.

UNITED STATES PATENT OFFICE.

FRANK RATTEK, OF DENVER, COLORADO, ASSIGNOR OF ONE-HALF TO
EDWARD T. SLEATH, OF SAME PLACE.

LOCOMOTIVE-ENGINE-WHEEL LATHE.

SPECIFICATION forming part of Letters Patent No. 463,995, dated November 24, 1891.

Application filed May 13, 1890. Serial No. 351,687. (No model.)

To all whom it may concern:

Be it known that I, FRANK RATTEK, a citizen of the United States, residing at Denver, in the county of Arapahoe and State of Colorado, have invented certain new and useful Improvements in Locomotive-Engine-Wheel Lathes; and I do declare the following to be a full, clear, and exact description of the invention, such as will enable others skilled in the art to which it appertains to make and use the same, reference being had to the accompanying drawings, and to the letters and figures of reference marked thereon, which form a part of this specification.

My invention relates to improvements in locomotive-engine-wheel lathes, and is especially designed for use in truing the wheels of locomotives after their peripheries have become so worn from use that it is ordinarily deemed necessary to send the engines to the shop for repairs.

The object of my invention is to true these wheels and put them in perfect condition for service without removing them from the engine during the operation. The practice heretofore has been, as is well known, to first take off the wheels, put them on a lathe, turn them as desired, and then put them back in place, making the work long, tedious, and expensive. It therefore seems desirable that some means should be devised whereby these wheels may be put in condition for use while they are still in position and without resorting first to the expedient of removing them from under the engines.

My improvement is believed to furnish a thoroughly practicable and reliable means for the accomplishment of this object, said means being at the same time comparatively simple in construction, economical in cost, easily practiced, effective in action, durable in use, and not liable to get out of repair.

To these ends my invention consists of the features, arrangements, and combinations hereinafter described and claimed.

In the drawings is illustrated an embodiment of the invention, in which drawings—

Figure 1 is a front view of a locomotive, partially in section, showing my improved mechanism in position for work. Fig. 2 is a top or plan view of the device, partially in

section, with the adjustable heads of the device removed. Fig. 3 is a vertical section taken on the line $x x$, Fig. 1, looking toward the left. Fig. 4 is a vertical section taken on the line $y y$, Fig. 1, looking toward the left, certain gears being shifted from the position shown in Fig. 1. Fig. 5 is an elevation, partially in section, of a clutch used in the mechanism. Fig. 6 is a face view of one part of the clutch. Fig. 7 is a top or plan view of one of the adjustable heads and its worm-gear connection. Fig. 8 is a side elevation, partially in section, of the same. Fig. 9 is an inner end view, and Fig. 10 is an outer end view, of the same. Fig. 11 is an elevation, partially in section, of a driving attachment used in connection with the adjustable heads for rotating the wheels operated upon. Fig. 12 is an end view of the same. Fig. 13 illustrates a detail of construction, being the box or bearing holding the worm-shaft in position, the box being secured to the head. Fig. 14 is a side elevation of a part of the mechanism. This view illustrates the construction and operation of a special form of tool for carrying out the purpose of the invention. Fig. 15 is an underneath view of the same. Fig. 16 is a section on the line $z z$, Fig. 14, looking toward the left. Fig. 17 is a detail view, on a large scale, of a part of the mechanism shown in Figs. 14, 15, and 16. Fig. 18 is a view of the mechanism for operating the special tools. Fig. 19 is a clutch mechanism used in connection with the shafting.

In the views, in which similar reference-characters indicate corresponding parts, the numeral 1 designates each of two adjustable lathe heads or frames secured to and adapted to slide upon a suitable stationary support 2. Heads 1 with their connections are illustrated in detail and on an enlarged scale in Figs. 7, 8, 9, and 10. The heads proper consist, preferably, of a single casting composed of a base 3, standards 4 4, and suitable braces 6 6 6. Secured to each of these heads by means of suitable bolts 7 is the journal-box 8, having a bearing 9, supporting the lathe spindle or shaft 10. The standards 4 are provided with vertical rabbets or ways upon which the bases of the journal-boxes

may slide vertically in order to be adjusted, being held in any position to which they may be adjusted by means of the bolts 7.

The center 11 of each lathe-spindle consists of a conical outer portion 15 and a shank 16, held by frictional contact within a suitable socket formed therefor within the center stock 12, which is adjustable horizontally by means of the screw-shaft 13, operated by the hand-wheel 14.

Mounted upon the spindle 10 and made fast thereto is the large worm-wheel 17, operated by the vertical shaft 18, having the worm portion 19 engaging the periphery of the wheel and held in contact therewith by the box or bearing S, through which the shaft 18 passes, box S being securely fastened to the head by means of suitable bolts W.

My improved device is double, there being two lathe-heads and their connections, one located on each side of the engine, as shown in Fig. 1, and in practice one of the centers 11 on each shaft or spindle 10 engages the extremity of the axle supporting the pair of wheels operated upon.

In Fig. 1 the center on the right is shown engaging the extremity of an axle 22, supporting a small pair of wheels 20, (one only being shown,) located under the forward portion of the engine, while the center on the left engages the extremity of an axle 23, upon which is mounted a larger pair of wheels 21, (one only being illustrated), located farther back from the front of the engine. It must be understood, however, that each axle is grasped by a pair of centers, one engaging each extremity, the two heads forming in effect a single lathe supporting an axle, a pair of turning-tools being so located and supported that both wheels may be simultaneously acted upon. The object of illustrating the two styles of wheels shown in Fig. 1 is to demonstrate the practicability of my improvement in operating upon wheels 21, supporting the cross-head, as well as its utility in handling the more exposed wheels 20.

Each worm-wheel 17 is provided with a driving attachment 71, composed of a face-plate M, having the cylindrical portions R, surrounding the outer extremity of the center stock 12. This device is secured to the face of worm-wheel 17. From part R projects a driving-arm 72, adapted to move behind the guide-bars and engage the wrist 73 or other suitable projection on the wheel acted upon while truing a wheel 21. While operating upon wheels 20 a second driving-arm 74 is used, being secured to arm 72 at right angles, and adapted to engage a lug 75, secured to the face of the wheel.

Each head 1, as before stated, is provided with a support 2, to which it is slidingly secured, and upon which it has a horizontal movement toward the end of the axle which its center engages and backward therefrom, as may be desired, this movement being ac-

complished by the use of mechanism which shall be now described.

25 is a belt leading from any suitable motor and passing over a loose pulley 26, mounted upon the shaft 27, suitably journaled, said shaft being further provided with the pulleys 28 and 29, secured to pulley 26, and therefore loosely mounted upon shaft 27. Leading from pulleys 28 and 29 to pulleys 30 and 31, mounted upon a shaft 33, are the belts 34 and 35, respectively. Shaft 33 is suitably journaled and supports a third pulley 32, loosely mounted thereon, pulleys 30 and 31 being rigidly secured to said shaft. Belt 34, connecting pulleys 30 and 28, is "crossed," so to speak, while belt 35, connecting pulleys 29 and 31, is direct-acting—that is, turns both pulleys in the same direction—while belt 34 turns the connected pulleys in opposite directions. Belts 34 and 35 are designed to propel shaft 33 in opposite directions. Hence when said shaft is in motion one of said belts must always be upon loose pulley 32. Shaft 33 is further provided near its opposite extremity with the bevel gear-wheel 36, meshing with another corresponding wheel 37, secured to one extremity of the shaft 38, suitably journaled and extending obliquely upward, its opposite or upper extremity being provided with the pulley 39, around which passes the cable 40, extending thence over pulley 41, around which it makes several turns, passing thence over guide-pulleys 42 and 43, around other guide-pulleys 42 and 43 on the opposite side of the mechanism, thence around another pulley 41 in a direction opposite from that taken in encircling the first pulley 41, and thence around another pulley 39 and back to the opposite side of the mechanism, passing over other guide-pulleys 43 and 42 in its course on both sides of the mechanism.

The bottom of each head 1 is provided with a projection 45, rigidly secured thereto and terminating at its lower extremity in a bearing 46, in which a spindle or short shaft is supported, said shaft being provided with a fast pulley 41 at one extremity and a small gear wheel or pinion A at the opposite extremity. This pinion A engages a stationary cogged rack B, formed on the side of a wall C forming a part of the support for housing 2, upon which the lathe-heads slide. Rack B is of sufficient length to permit heads 1 the desired longitudinal or lateral movement. The movement of the cable transmits motion to pulley 41, around which pulley the cable makes several turns to increase the friction and insure proper action of the pulley. Motion is communicated to pinion A from pulley 41, and said pinion travels along rack B, giving the desired movement to the lathe-heads 1 and their attachments, the two heads moving in opposite directions by reason of the reverse manner in which the two pulleys 41 are encircled by the cable, as before described. Hence during the movement of the

cables the heads 1 will approach each other or recede from each other, according as motion from shaft 27 is transmitted to shaft 33 by belt 34 or 35, since these pulleys impart motion to shaft 33 and thence to the cable in opposite directions. Shaft 33 is provided at its inner extremity with a clutch-wheel 47, adapted to engage a corresponding clutch-wheel 48, made fast to the adjacent extremity of a shaft 49, extending to the opposite side of the machine and suitably journaled. This shaft is provided with two bevel gear-wheels 50 50, one located on each side of the mechanism and each meshing with another similar wheel 51, mounted upon a shaft 52, extending obliquely upward, its opposite extremity being provided with a gear-wheel 53, meshing with a similar wheel 54, made fast to one extremity of a shaft 55, the opposite extremity of this shaft being provided with a bevel gear-wheel 56, meshing with a corresponding wheel 57, secured to the lower extremity of a vertical screw-shaft 58, by means of which the box 8 of each head is adjusted vertically, the box 8 being provided with a threaded socket 59, through which screw-shaft 58 passes.

Returning now to shaft 27, I will suppose the motor-belt 25 shifted from loose pulley 26 to fast pulley 60, as shown by dotted lines, motion being thereby transmitted to shaft 27 and to cone-pulley 61, which is made fast thereon. Pulley 61 is connected by means of a belt 62 with another cone-pulley 63, made fast upon a shaft 64, provided with a clutch-pulley 76, or the cone-pulley may be loose upon the shaft and motion communicated thereto by means of the back gearing represented by the cog-wheels *a*, *b*, *c*, and *d*, suitably supported and connected, as shown. Pulley 76 is adapted to engage a clutch-wheel 85, secured to the adjacent extremity of a shaft 150, extending from one side of the mechanism to the other, and provided with two bevel gear-wheels 65, meshing with similar wheels 66, secured to the lower extremities of vertical shafts 18, each provided with the worm portion 19 for imparting motion to wheels 17, to which reference has been heretofore made.

It must be observed that the gear-wheels 56 and 65 are secured to their respective shafts by means of splines, and are thus permitted a longitudinal movement during the lateral or horizontal adjustment of the lathe-heads.

67 and 68 are collars surrounding shafts 18 and 150, respectively. These collars are united or connected by the web 69, which is secured to the bottom of the heads in any suitable manner, as by bolts. This connection between wheels 65 and 66 retains them in operative relation at all times during the lateral adjustment of the heads, since the collar 68 is in contact with wheel 65. Wheels 56 and 57 are connected by a similar mechanism and operated in a similar manner, as shown. The clutch-pulley 76 on shaft 64 is connected by means of a belt 77 with a pulley 78, made fast to a shaft 79, suitably journaled and extend-

ing parallel and lying in the same horizontal plane with shaft 64.

Shaft 79 extends from one side of the mechanism to the other, and is provided with gear-wheels 80 80, meshing with two other similar gear-wheels 81 81, made fast to the lower extremity of the vertical shaft 82 82, connected with the carriages 83, having adjustable chucks 93. These chucks carry the tools 84 for operating upon the wheels 20 and 21. It must be observed that the vertical shaft 82 is only used in connection with the special tools illustrated in Figs. 14, 15, and 16, where the tool consists of a wheel to which motion must be transmitted from shaft 79 while cutting or grinding, the ordinary tools remaining stationary while truing the rotating wheels of the locomotive.

As before stated; shaft 150 is provided with a clutch 85, slidingly secured thereon by means of a spline and rotating therewith, being located close to the clutch-pulley 76; and their adjacent faces fashioned as shown in Figs. 5 and 6 and adapted to engage each other when it is desired to transmit motion from shaft 64 to shaft 150.

In Fig. 14 and other views on the same sheet I have illustrated my special tools before referred to, consisting of two milling or emery wheels 87 and 107 and means for operating the same. The purpose of these tools is for cutting or grinding the engine-wheels either in the direction of their peripheries, as when wheel 107 is used, or across the same for the purpose of forming facets when the wheel 87 is used. In introducing this new form of tool some additional mechanism is necessary, which will be now described. To the top of shaft 82 is secured the bevel gear-wheel 88, meshing with another similar wheel 89, secured to the extremity of a horizontal shaft 90, provided with the milling-wheel 87, supported by an arm 92, secured to a chuck or block 93, vertically adjustable within the carriage 83 by means of the hand-crank 86, the entire carriage 83 being adjusted horizontally by hand-crank 108.

In Fig. 17 is illustrated on a large scale the connection between gear-wheels 88 and 89. The object of this view is to illustrate a construction permitting the vertical adjustment of wheel 87 without disengaging gear-wheels 88 and 89. The upper portion 100 of shaft 82 is formed angular, preferably square, and is surrounded by the sleeve 101, formed integral with gear-wheel 88. This sleeve is provided at its bottom with the exteriorly-projecting flange 102, and is surrounded by a collar 104, contained between the flange 102 and the lower surface of gear 88. Collar 104 is connected with a similar collar 105 on shaft 90 by means of the web 106. Thus if shaft 90 is raised gear-wheels 88 and 89 move together in operative position. The means of adjusting chuck 93 vertically and the entire carriage 83 horizontally by the hand-cranks 86 and 108 has already been re-

ferred to. This horizontal adjustment by hand is accomplished by communicating motion directly to pinion 110 by turning crank 108, said pinion being located on shaft 130, to which the crank is secured. The pinion 110 engages a corresponding cogged stationary rack 111, thereby giving the horizontal movement to sliding carriage 83. The vertical adjustment of block 93 is accomplished by turning the screw-shaft 95 within a threaded aperture formed in the block. The required motion is given by hand to shaft 95 by turning crank 86, provided with the gear-wheel 114, meshing with a similar wheel 113, made fast to the lower extremity of screw 95. This adjustment of the carriage 83 and of the chuck 93 within the carriage is, however, accomplished by connecting shaft 79, heretofore described, with a worm-shaft 117, journaled within the stationary frame-work. This is accomplished by the use of a belt 118, leading from a cone-pulley 115 on shaft 79 to a similar pulley 116, secured to shaft 117. The other mechanism by which this operation is carried out is best illustrated in Fig. 18. Referring now to this view, worm-shaft 117 passes between worm-wheels 118 and 119, mounted upon suitable shafts, each of which is provided with a small gear-wheel 120, adapted to mesh with a gear-wheel 121 upon a shaft 122, provided with a gear-wheel 123, meshing with a similar wheel 124 upon the shaft 125, suitably journaled and extending obliquely upward, its upper extremity being provided with a worm portion 126, engaging worm-pulley 109, and transmitting motion to pinion 110. During the hand adjustment of shaft 130 pulley 109 is loose upon the shaft; but while operated by the worm-shaft 125 the pulley must be locked upon the shaft in some suitable manner. Shaft 122 is provided with a worm 127, engaging a corresponding pulley 128, made fast upon vertical screw-shaft 95.

It must be observed that only one worm-wheel 118 or 119 is in contact with shaft 117 at the same time, the object of both worm-wheels being to reverse the motion of shaft 122 at will. This is accomplished by any suitable means for disengaging one of these pulleys from shaft 117 and at the same time bringing the other pulley into engagement with said shaft. By means of changing the movement of shaft 122 the carriage 83 is moved in either direction horizontally and the block 93 in either direction vertically.

From the description heretofore given it is believed that the operation of the mechanism will be readily understood. The side or connecting rods of the wheels of the locomotive are first removed. The locomotive is then run in upon the track F, so that a pair of wheels may stand between the two lathe-heads. The locomotive is then elevated, so as to raise the wheels off the rails, by a suitable jack H, the upper ends of which are arranged to bear under the axles of their re-

spective wheels. The spring which supports the locomotive upon the axle-bearings is then blocked up underneath by means of suitable supports so as to sustain the body of the locomotive, after which the sections of the track upon which the locomotive has been run are removed. The axles of the wheels are then lowered in their bearings and the cutter-heads moved by means of the cable 40, so as to clamp their supporting-frames in any convenient manner. The lathe-centers of the respective heads are then adjusted by means of the screw-shaft 58, after which they are tightened upon the extremities of the axle. Motion is then communicated to the large worm-wheel 17, and thence to the wheels operated upon, in the manner hereinafter described. It must be observed that while using the ordinary stationary tools for truing the wheels the locomotive-wheels are kept continually in motion; also, that while using the milling or emery wheels 87 for cutting across the periphery of the wheels, as in forming facets, the engine-wheels remain stationary; and, further, that while grinding or cutting by means of wheel 107 with the plane of the locomotive-wheels these wheels 20 and 21 are rotated in the same manner as when the ordinary stationary tools are used. The facets formed by cutting the periphery should be at regular intervals thereon. Hence wheels 17 are graduated, as shown at J, Fig. 9, and provided with a suitable stationary pointer K. The pointer will therefore indicate on the circle the exact distance of turning the wheel operated upon, and enable the operator to adjust the mechanism so as to cut the facets at proper and regular distances upon the wheel's periphery.

Having thus described my invention, what I claim is—

1. In an engine-wheel lathe, the movable heads 1, provided with a suitable stationary support and having the projections 45, terminating in a bearing provided with a suitable spindle or shaft, on which are mounted a pinion A and a pulley 41, both fast upon the shaft, a cogged rack B of suitable length, which rack the pinion engages, and an endless cable 40, suitably supported and propelled, and in its course surrounding pulleys 41 in such a manner as to cause the heads 1 to recede from or approach each other simultaneously, substantially as described.

2. In an engine-wheel lathe, the heads 1, having spindles mounted thereon and supported in vertically-adjustable bearings, a vertical screw-shaft having a threaded connection with each of these bearings, and suitable means of imparting motion to said screw-shaft and adjusting the bearings of heads 1, substantially as described.

3. A tool for cutting or grinding the wheels of locomotive-engines, consisting of a milling or emery wheel 87, a horizontal shaft 90, sup-

porting said wheel and provided with a gear-wheel 89, a vertical shaft 82, provided with a gear-wheel 88, meshing with wheel 89, shaft 82 being angular at the top and provided with a sleeve 101, adapted to slide vertically thereon and made fast to wheel 88, a collar 104, surrounding said sleeve, a collar 105, surrounding shaft 90, a web 106, connecting said collars, and suitable means of vertically adjusting shaft 90 and its connections, substantially as described.

4. In an engine-wheel lathe, the movable heads 1, provided with suitable stationary supports, spindles supported thereon and provided with adjustable center-stocks and centers retained therein, propelling-wheels 17, mounted upon the spindles, and a face-plate M, secured to the face of the wheels 17 and provided with the cylindrical part R, having the arm 72, which drives the wheel operated upon, substantially as described.

5. In an engine-wheel lathe, the movable heads 1, slidingly secured to suitable supports and provided with journal-boxes adjustably secured thereto, spindles supported by said boxes and provided with adjustable centers for grasping the axle, having gear-wheels thereon, and propelling-wheels mounted upon the spindles and provided with suitable attachments for driving the wheels operated upon, in combination with a system of shafting, whereby the heads are moved horizontally, the centers adjusted vertically, and the re-

quired movement communicated to the propelling-wheels, substantially as described. 35

6. In an engine-wheel lathe, the combination of the heads having vertically-adjustable bearings thereon, spindles mounted in the said bearings, a threaded vertical shaft passing upward through the bearings of each of the said heads, whereby the bearings may be raised or lowered, a shaft, and connecting mechanism simultaneously acting upon the said vertical shafts, a propelling-wheel mounted on each of the said spindles, a vertical spline shaft 18 near each of the said propelling-wheels, and a worm vertically movable on each of the said spline shafts and engaging the wheel contiguous thereto, as described. 40 45

7. In an engine-wheel lathe, the combination of the heads having vertically-adjustable bearings therein, spindles mounted in the said bearings, means whereby the said heads may be simultaneously raised or lowered, a propelling-wheel mounted on each of the said spindles, a vertical spline shaft 18 near each of the said wheels, and a worm vertically movable on each of the said shafts and engaging the wheel contiguous thereto, as described. 50 55

In testimony whereof I affix my signature in presence of two witnesses. 60

FRANK RATTEK.

Witnesses:

FRED. W. FELDWISCH,
WM. MCCONNELL.